

## KUDOS USA DIES AHE FOR HYDRAULIC CRIMPERS

- For LEC-U27, LEC-32, LEC-40, LEC-44, UB-400(HE), UCP-2712(HE), UB-412(HE), H-412HE, HYCP-4413(HE), ADP-15THE, ADP-630HE, ADP-451000HE

### • Hex Dies for Copper Lugs

Suitable for TERMINALS with wall thickness little less than DIN 46235 Cable Lugs

Unit: mm

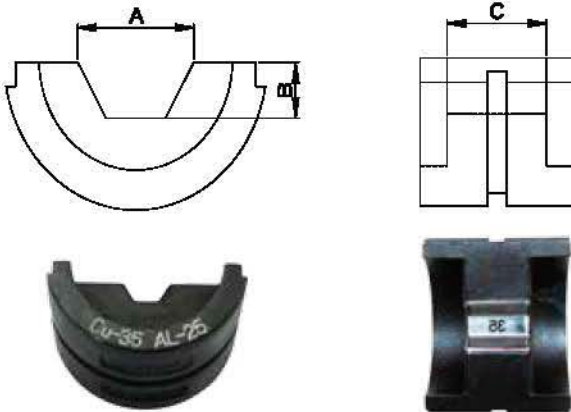

Die No.	A	B	C
CU-16	7.20	3.12	14.00
CU-25	8.43	3.67	14.00
CU-35	10.00	4.33	16.00
CU-50	11.60	5.02	16.00
CU-70	13.70	5.95	15.60
CU-95	15.90	6.85	15.70
CU-120	17.98	7.79	16.00
CU-150	20.10	8.70	15.00
CU-185	22.33	9.67	14.00
CU-240	25.43	11.01	13.00
CU-300	28.44	12.32	11.20
CU-400	30.00	14.55	11.50

### • Hex Dies for Solderless Terminals

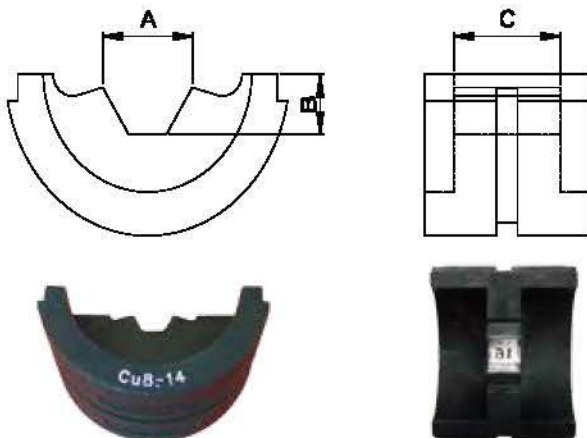

Unit: mm

Die No.	A	B	C
CU-8-14	7.40	3.50	8.00
CU-22	8.80	4.30	10.00
CU-38	11.50	5.40	11.50
CU-60-70	13.40	6.00	15.00
CU-80	15.00	6.75	18.00
CU-100	18.00	8.00	15.00
CU-150-180	21.00	9.10	13.00
CU-200	28.44	12.32	11.20
CU-325	30.00	14.56	11.50

- For LEC-185T, LEC-240T, K-185, K-240, HYCP-185(HE), HYCP-240(HE)

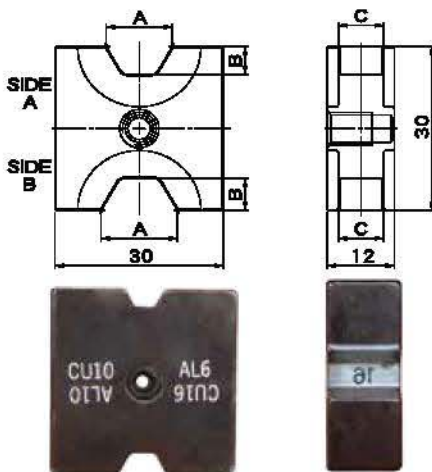

Unit: mm

Die No.	Side		A	B	C
AHE-1016	A	CU10	5.45	2.30	12.00
	B	CU16	6.80	2.85	12.00
AHE-2535	A	CU25	8.35	3.50	9.00
	B	CU35	9.40	4.00	9.00
AHE-5070	A	CU50	11.35	4.80	9.00
	B	CU70	13.80	6.05	9.00
AHE-95120	A	CU95	16.17	6.90	9.00
	B	CU120	18.05	7.60	9.00
AHE-150	A	CU150	20.15	8.55	6.00
AHE-185	A	CU185	22.15	9.35	6.00
AHE-240	A	CU240	22.15	9.35	6.00

- AHE-240 Die For 240 Series Only.